

# Rental LED Display

## NG500/1000 Series

NG500/1000 series rental LED display features a new design that incorporates many aesthetic elements and adopts high-strength die-casting aluminum, weighing only 7.5kg per cabinet. It offers better performance with a high-definition visual display.

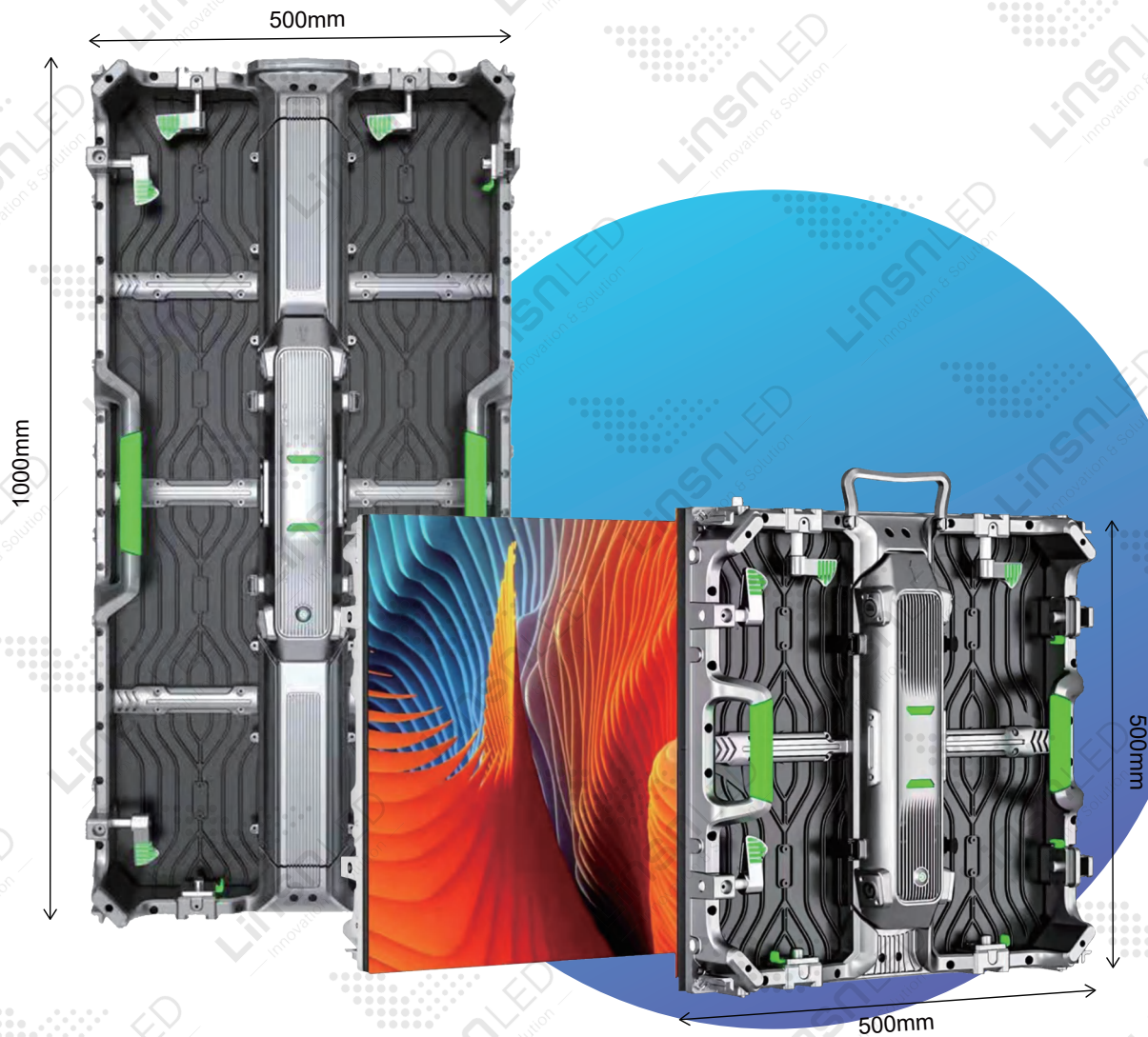

NG-P2.604/2.976/3.91/4.81

# NG500/1000 Series Rental LED Display

## Lightweight and Thin

Portable and stable, with a **weight of 7.5kg per cabinet** and a **thickness of 80mm**. The lightweight feature makes the LED display easy to carry, transport, and install, saving a good amount of money on labor costs.

## Perfect Structure

We have the top domestic design team. The design innovation has its own unique philosophy, with a number of core technologies. The innovative structural design and avant-garde body lines give you an extraordinary experience.

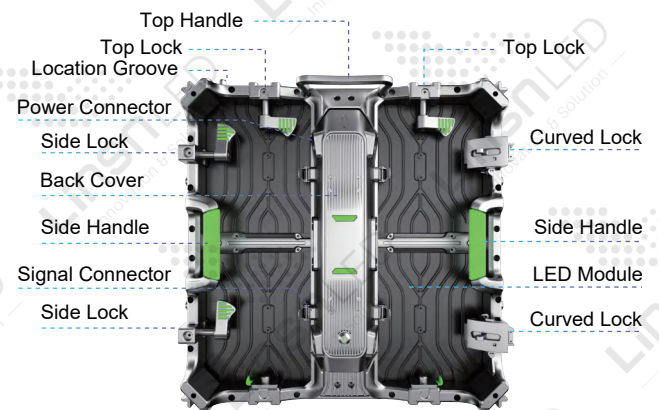
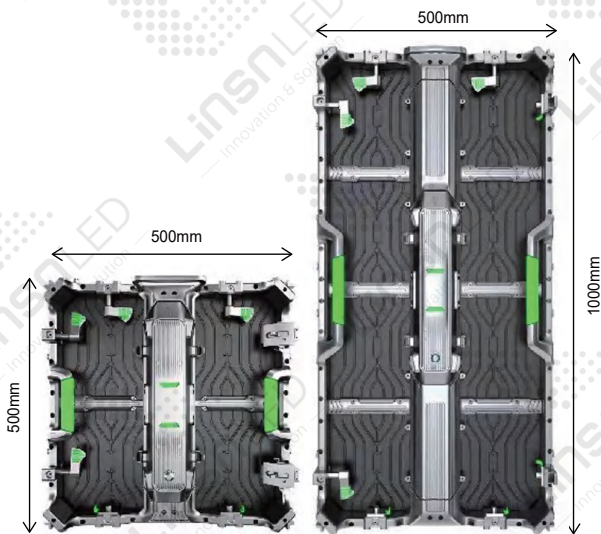

## Right-angle Installation (Optional)

Supports **90°** right angle LED display installation to meet some special buildings and applications.



## Detachable Back Cover

Adopts optimized control box with quick removable option, without any tools required. The back box (includes power supply and control cards) can be quickly removed for replacement and maintenance.

## Frontal and Rear Double Service Design

NG500 series rental LED display is a dual maintenance product, not only 100% front accessible but also capable of rear service. The LED panels are magnetic and can be removed from the front side in 5 seconds with tools, making it easy and convenient, saving you costs and labor.

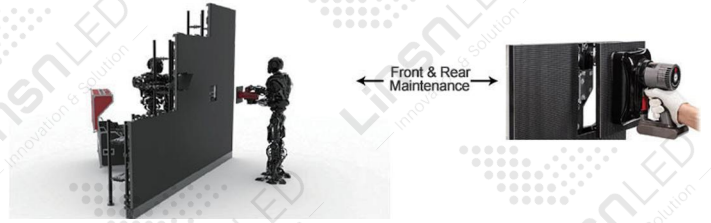

## Seamless Display and Better Visual Effects

The high-precision aluminum cabinet frame ensures seamless splicing of images and video displays, offering you the perfect visual experience from any angle. The picture quality provides viewers with an entirely new sensory experience.

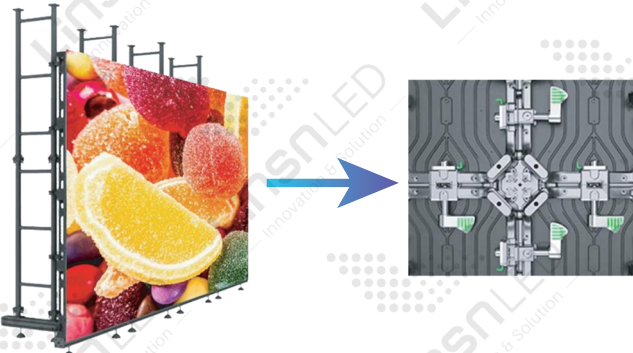

## Curved Installation (Optional)

In order to meet various aspects of the LED screen field, the NG500/1000 series LED display is designed for curved installation. **The curved lock can achieve 2.5° at intervals within the range of -10° to 15°**, enabling both convex and concave configurations.

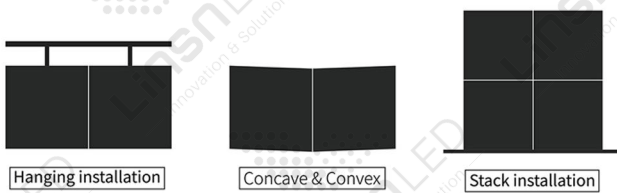
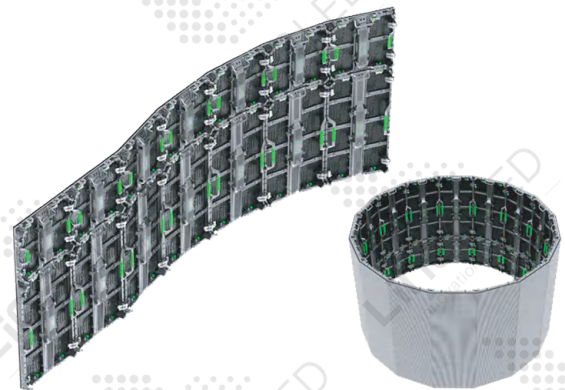

## Multiple Installation Methods for Cabinets

Supports three installation methods for the cabinet: hanging installation, concave and convex installation, and stack installation.

## IP65 Waterproof

IP65 waterproof protection on the front side ensures continuous and stable operation in all kinds of outdoor environments.

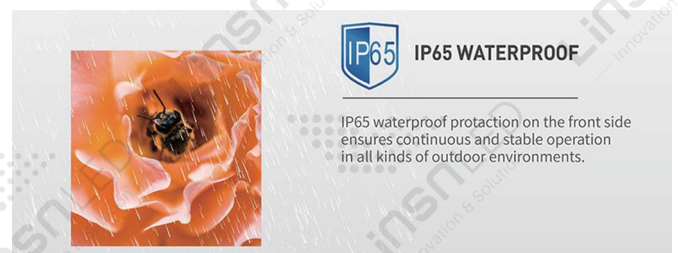

High Quality With Global Standards,  
CE EMC, RoHs, FCC Certificated.

## Specification

Pixel Pitch	P2.604mm	P2.976mm	P3.91mm	P4.81mm
Pixels per cabinet	192×192 (HxV)	168×168 (HxV)	128×128 (HxV)	104×104 (HxV)
LED lifetime	100,000h			
Brightness (for indoor)	800 nits	800 nits	700 nits	700 nits
Brightness (for outdoor)	4500 nits			
Module size	250×250mm			
Module resolution	96×96dots	84×84dots	64×64dots	52×52dots
Refresh rate	3,840Hz			
Hor. viewing angle	140° +/-5° (@50% brightness)			
Vert. viewing angle	140° +/-5° (@50% brightness)			
Brightness uniformity	>98%			
Dimming	0-100%			
Grey Level	14 bits			
Avg Power consumption	350 W/m <sup>2</sup>	320 W/m <sup>2</sup>	300 W/m <sup>2</sup>	280 W/m <sup>2</sup>
Max Power consumption	Indoor: 450 W/m <sup>2</sup> , Outdoor: 640 W/m <sup>2</sup>			
Operation power voltage	100-240V/50-60Hz			
Operational temperature	-10°C to +40°C/14°F to 104°F			
Operational humidity	10-80%			
IP rating	IP50 for Indoor, IP65 for Outdoor			
Dimensions	500 x 500 x 80 mm/500 x 1000 x 80 mm (WxHxD)			
Weight / Tile	7.5 kg/14 kg			
Serviceability	Front and back service			
Certifications	CE, UL, FCC class A, RoHS, WEE, REACH			